



SHAKER

MDF DOOR TOOLING

- > Perfect-finish, one-piece MDF Shaker door - as featured at IWF, AWFS & Ligna
- > Increase your production throughput and eliminate sanding
- > 5-piece PCD diamond tool set
- > Tools can also be purchased individually

1. Shaker-Hogout

PART NO: DRS01-D01

Removes material from the pocket and leaves a smooth, clean surface

2. Shaker-Inside Radius

PART NO: DRS01-D02

Removes material from the perimeter of the pocket

3. Shaker-Corner

PART NO: DRS01-D03

Refines the inner corners of the pocket

4. Shaker-Highlight

PART NO: DRS01-D04

Cuts the fine line that gives the appearance of a traditional 5-piece cabinet door

5. Shaker-Cutout+Radius

PART NO: DRS01-D05

Cuts the overall outside shape of the door, leaving a clean outside edge with a small top radius

1. Shaker - Hogout

PART NO: DRS01-D01

Removes material from the pocket and leaves a smooth, clean surface

2. Shaker - Inside Radius

PART NO: DRS01-D02

Removes material from the perimeter of the pocket

3. Shaker - Corner

PART NO: DRS01-D03

Refines the inner corners of the pocket

4. Shaker - Highlight

PART NO: DRS01-D04

Cuts the fine line that gives the appearance of a traditional 5-piece cabinet door

5. Shaker - Cutout+Radius

PART NO: DRS01-D05

Cuts the overall outside shape of the door, leaving a clean outside edge with a small top radius

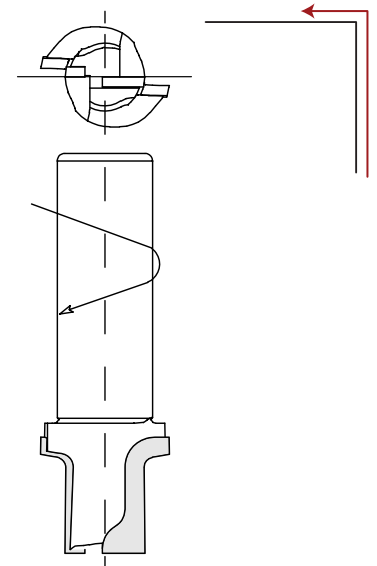
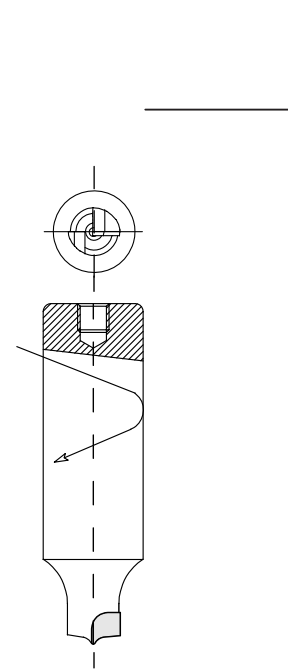
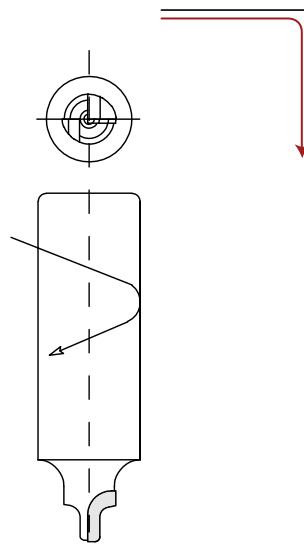
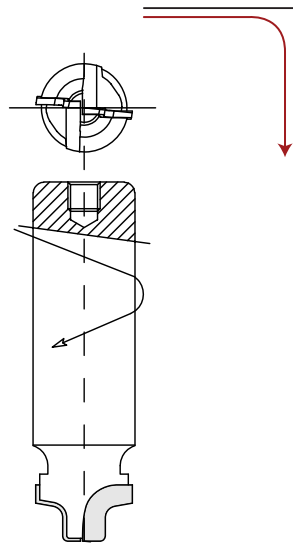
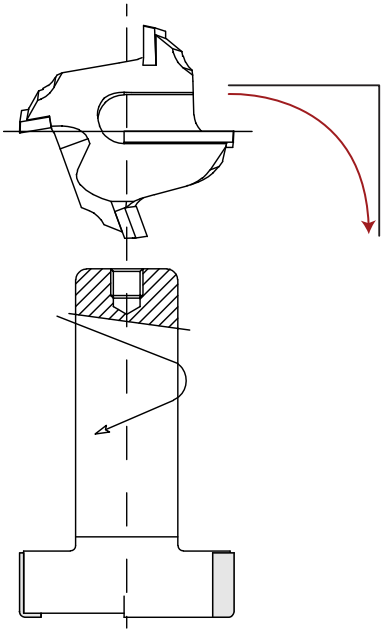

CED 40.0 mm
CEL 8.5 mm
SHANK 19.05 mm (3/4")
CE/Z 3+1

CED 18.0 mm
CEL 8.5 mm
SHANK 19.05 mm (3/4")
CE/Z 2

CED 10.0 mm
CEL 8.5 mm
SHANK 19.05 mm (3/4")
CE/Z 1

CED 10.0 mm
CEL 6.0 mm
SHANK 19.05 mm (3/4")
CE/Z 1

L. DIAM 26.0 mm
S. DIAM 16.0 mm
CEL 19.05 mm
SHANK 19.05 mm (3/4")
CE/Z 2