



ACCESSORIES



PRODUCT CATEGORY	PAGE NO.
BALL BEARING GUIDES	H1
BUSHINGS FOR SAW BLADES	H2
FLANGED SLEEVES	H2
FLANGES FOR CIRCULAR SAW BLADES	H3
MECHANICAL SLEEVES	H3
SLEEVES	H1
SPACERS	H1

PART NO.	PAGE NO.
054-3175-1 - 054-40-3175	H2
058-114001 - 058-040138	H2
W057114-3 - W057114-80	H1

METRIC I.D.

OUTSIDE DIAM. ØD MM	INSIDE DIAM. ød
50	30
55	35
60	40
70	50

IMPERIAL I.D.

OUTSIDE DIAM. ØD MM	INSIDE DIAM. ød
50	1-1/4"
55	1-3/8"
60	1-9/16"
70	1-13/16"

THICKNESS

THICKNESS B MM	THICKNESS B INCH
0.1 - 0.2-0.5 - 1.0	.004" - .008" - .020" - .040"
2.0	.040"
5.0	3/16"
10.0	25/64"
8.1-20	5/16"-3/4"
20.1-30	53/64"-1-3/16"
30.1-40	1-3/16"-1-9/16"
40.1-50	1-9/16"-2"

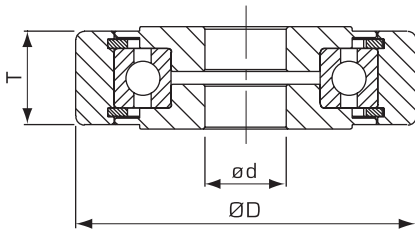
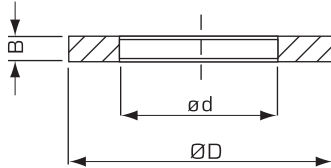

PART NO.	OUTER DIAM. ØD	INNER DIAM. ød	THICKNESS T
W057114-3	3"	1-1/4"	7/8"
W057114-4	4"	1-1/4"	7/8"
W057114-80	80mm	40mm	18mm

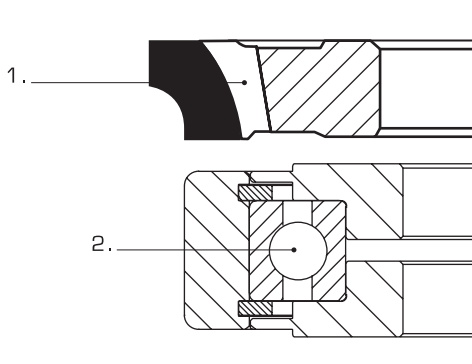

1 = CUTTER
2 = BALL BEARING GUIDE

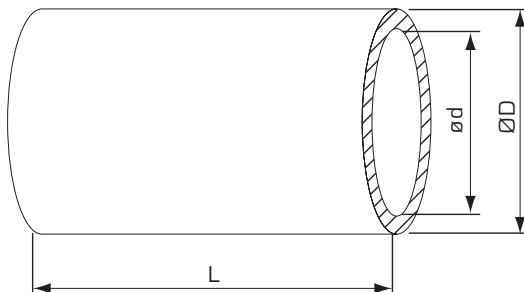

IMPERIAL I.D.

OUTSIDE DIAM. ØD	INSIDE DIAM. ød
1-1/4"	3/4"
1-13/16"	1-1/4"

METRIC I.D.

OUTSIDE DIAM. ØD MM	INSIDE DIAM. ød MM
35	30
40	30-35
50	30-40

LENGTH

L MM	L INCH
2	5/64"
5	3/16"
10	3/8"
15	5/8"
20	3/4"
30	1-3/16"

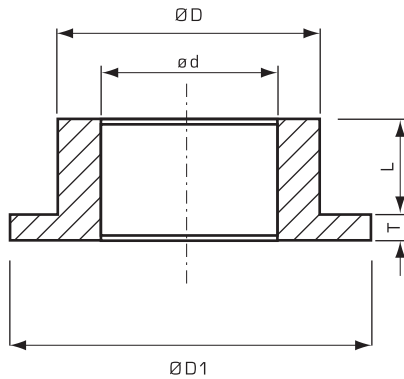

PART NO.	OUTER DIAM. ØD	INNER DIAM. ød	FLANGE DIAM. ØD1 MM	FLANGE THICK. T MM	LENGTH L MM
054-3175-1905	1-1/4"	3/4"	52	5	20
054-3175-34	1-1/4"	3/4"	45	3	15
054-3175-254	1-1/4"	1"	52	5	20
054-3175-1	1-1/4"	1"	45	3	15
054-40-3175	40mm	1-1/4"	60	5	20

Other sizes available upon request

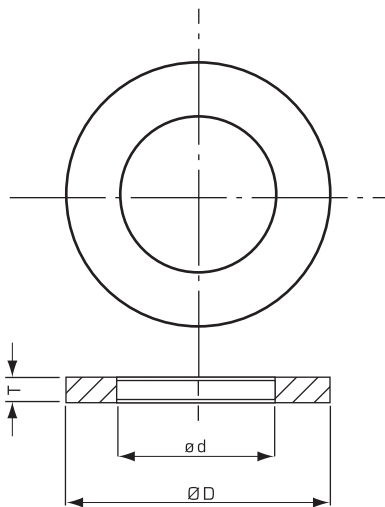

PART NO.	OUTER DIAM. ØD	INNER DIAM. ød	THICKNESS T MM
058-114001	1-1/4"	1"	2.1
058-114034	1-1/4"	3/4"	2.1
058-114058	1-1/4"	5/8"	2.1
058-118001	1-1/8"	1"	2.1
058-001034	1"	3/4"	2.1
058-001058	1"	5/8"	2.1
058-020038	20mm	3/8"	2.1
058-020058	20mm	5/8"	2.1
058-022020	22mm	20mm	2.1
058-022034	22mm	3/4"	2.1
058-022058	22mm	5/8"	2.1
058-034058	3/4"	5/8"	2.1
058-030001	30mm	1"	2.1
058-030034	30mm	3/4"	2.1
058-030058	30mm	5/8"	2.1
058-032020	32mm	20mm	2.1
058-040114	40mm	1-1/4"	2.1
058-040138	40mm	1-3/8"	2.1

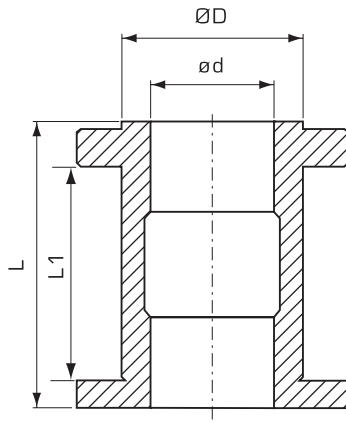

SPECIAL PRODUCTION

OUTER DIAM. ØD MM	INNER DIAM. ød	USABLE LENGTH L1 MM	OVERALL LENGTH L MM	ROTATION
50	1-1/4"	70	90	RH/LH
50	1-1/4"	85	105	RH/LH
50	1-1/2"	85	105	RH/LH
50	40mm	70	90	RH/LH
50	40mm	90	112	RH/LH
60	1-1/4"	85	105	RH/LH
60	1-1/2"	85	105	RH/LH
60	40mm	90	112	RH/LH

Other sizes available upon request

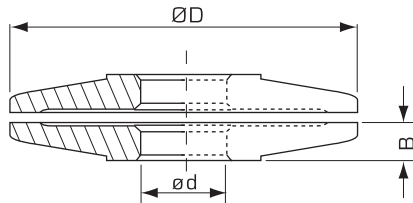

ØD MM	ød MM	ØD INCH	ød INCH
60	30	2-3/8"	5/8" - 1"
80	30	3-1/8"	5/8" - 1"
100	30	4"	5/8" - 1"
125	30	5"	5/8" - 1"
150	30	6"	5/8" - 1"